

Typical Features

- ◆ Wide input voltage range, non-isolated regulated single output
- ◆ Efficiency up to 96% (Typ.)
- ◆ Low no-load power consumption, available for negative output.
- ◆ High power density, Mini size SIP package.
- ◆ Over-temperature protection, short circuit protection.
- ◆ Operating temperature from -40°C to +95°C.
- ◆ Plastic case, flame class UL94-V0



Application Field

This series of products can be widely used in the fields of Instrument, communication, pure digital circuits, general low-frequency analog circuit, relay drive circuits, data exchange circuits and other fields.

Typical product List

Certificate	Part No.	Input Voltage Range		Output Voltage/Current (Vo/Io)		Max. Capacitive Load (μF)	Efficiency (%) @Full load,	
		Nominal (VDC)	Range (VDC)	Vo (VDC)	Io (mA)		Vin (Min.)	Vin (MAX)
-	K7803M-3000R3	24	6.5-32	3.3	3000	4700	90	87
		12	6.5-27	-3.3	-2000	2200	83	86
	K7805M-3000R3	24	6.5-32	5	3000	4700	91	89
		12	6.5-27	-5	-2000	2200	85	88
	K7809M-3000R3	24	12-32	9	2500	2200	92	92
		12	8-23	-9	-1000	1000	87	89
	K7812M-3000R3	24	15-32	12	2500	2200	94	93
		12	8-20	-12	-1000	1000	84	86
	K7815M-3000R3	24	18-32	15	2500	1000	93	92
		12	10-17	-15	-1000	470	85	87

Note 1: When input voltage exceeds 27VDC, connect an external 47μF/50V electrolytic capacitor to the input terminal to prevent module damage from voltage spikes.

Note 2: The Ripple & Noise is tested by the twisted pair method.

Input Specifications

Items	Test Condition		Min	Typ.	Max	Unit
No load input current	Full input voltage range	Positive output	-	0.2	1.5	mA
		Negative output	-	1	4	mA
Full load input current	Output 3.3V		-	474	1731	mA
	Output -3.3V		-	640	1254	mA
	Output 5V		-	702	2653	mA
	Output -5V		-	950	1854	mA

	Output 9V	-	1019	2083	mA
	Output -9V	-	843	1324	mA
	Output 12V	-	1344	2174	mA
	Output -12V	-	1163	1829	mA
	Output 15V	-	1698	2289	mA
	Output -15V	-	1437	1807	mA
Input reversed	Not allowed				
Input filter	Capacitor Filter				
Hot-plug	Unavailable				

Output Specifications

Items	Test Condition		Min	Typ.	Max	Unit
Output voltage accuracy	Full input voltage range, 0%-100% load		-	±1	±2	%
Line voltage regulation	Full input voltage range, 100% load		-	±0.3	±0.5	%
Load regulation	10%-100% load	Positive output	-	1	2	%
		Negative output	-	2	3	%
Transient response deviation	25% rated load step, nominal input voltage		-	50	300	mV
Transient recovery time			-	0.2	1	ms
Temperature drift coefficient			-	-	±0.03	%/°C
Ripple & Noise	0%-100% load, 20MHz bandwidth	3.3V, 5V output	-	40	75	mVp-p
		others	-	100	150	mVp-p
Over current protection	Full input voltage range		-	200	-	%Io
Short circuit protection	Continuous, self-recovery					

Note: Ripple & Noise is tested by the Twisted Pair Method, please refer to the following test instruction.

General Specifications

Items	Test Condition	Min	Typ.	Max	Unit
Switching frequency	Nominal input voltage, full load	-	300	-	KHz
Operating temperature	Refer to the Temperature Derating Graph (figure 1)	-40	-	+95	°C
Storage temperature	/	-55	-	+125	
Case temperature	Within the operating derating range	-	-	110	
Pin soldering temperature	1.5mm from the case, soldering time 10S	-	-	300	
Relative humidity	No condensing	5	-	95	%RH
Vibration	10-150Hz, 5G, 30 Min. along X, Y and Z				
MTBF	MIL-HDBK-217F@25°C	1000	-	-	K hours
Case material	Plastic in black, flame class UL94-V0				
Unit weight	2.6g(Typ.)				
Cooling method	Nature Air				
Package method	Single tube (526*9.5*17mm)	35PCS			

	Single tube (542*110*155mm)		2800PCS(Total 80 tubes)
Unit dimensions	L × W × H	14.0×7.6×10.2mm	0.551×0.299×0.402inch

EMC Performance

Items		Test Standard	Performance/Class
EMC	EMI	CE	CISPR32/EN55032 CLASS B (with the Recommended EMC Circuit)
		RE	CISPR32/EN55032 CLASS B (with the Recommended EMC Circuit)
	EMS	ESD	IEC/EN61000-4-2 Contact ±8kV perf.Criteria B

Mechanical Dimensions

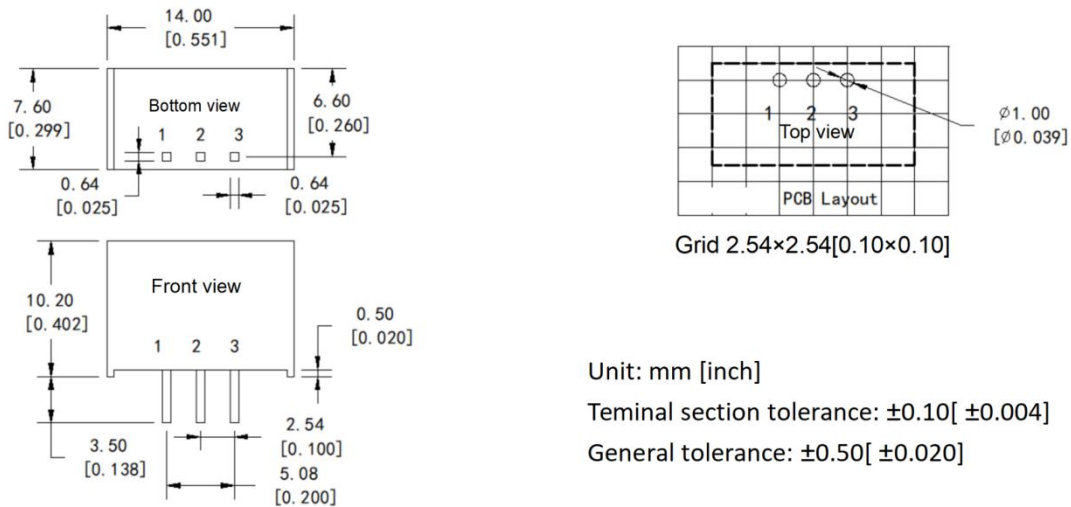

Pin Function Description

Pin No.	1	2	3
Positive output	+Vin	GND	+Vo
Negative output	+Vin	-Vo	GND

Note: Please take the pin definition on the product label as the right one if it is different than the data sheet description.

Ripple & Noise Test Procedure (Twisted Pair Method, 20MHz Bandwidth)

Test Method:

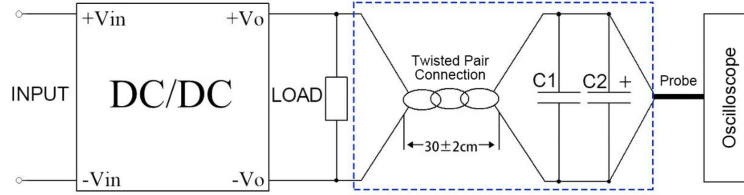

1. Ripple noise is measured using a #12 twisted pair cable. Set the oscilloscope bandwidth to 20MHz with 100M bandwidth. Remove the probe cap and ground wire. Connect C1 (0.1μF polypropylene capacitor) and C2 (10μF high-frequency low-impedance electrolytic capacitor) in parallel at the probe end. Use the Sample mode for oscilloscope sampling.

2. Output Ripple Noise Test Diagram: Connect the power supply input to the input power source. The power supply output connects to the electronic load via a fixture board. For testing, use a 30cm ± 2cm sampling lead to directly sample from the power supply output port. Select insulated wires with appropriate gauge based on the output current.

Application Reference:

1. Maximum capacitive load values are obtained under pure resistive full-load conditions;
2. Minimum 10% load or connection of a high-frequency, low-resistance electrolytic capacitor ($\geq 100\mu\text{F}$) is recommended to prevent increased output voltage ripple and noise;
3. Our company offers complete power supply solutions or product customization. Due to space limitations, please contact our relevant personnel for any other inquiries.

Temperature Derating Graph

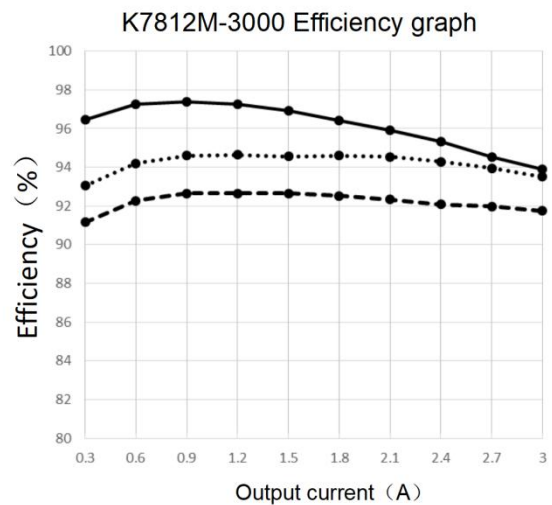
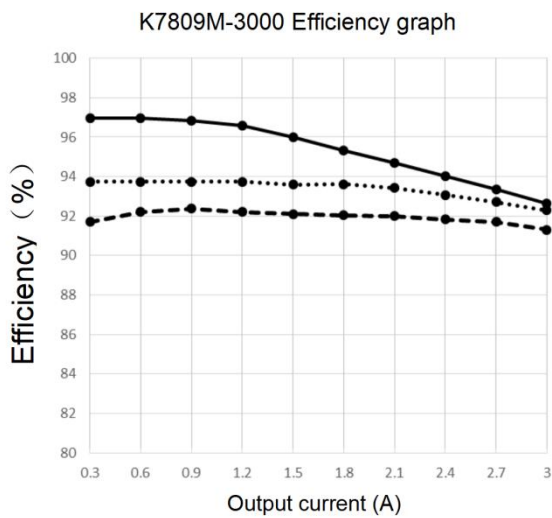
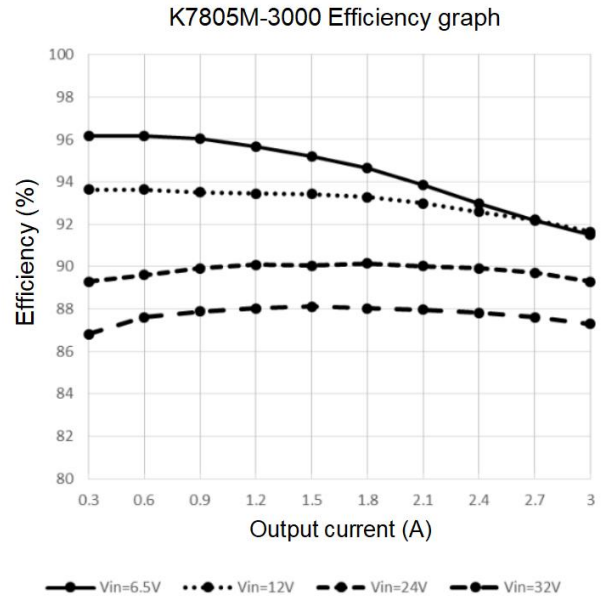
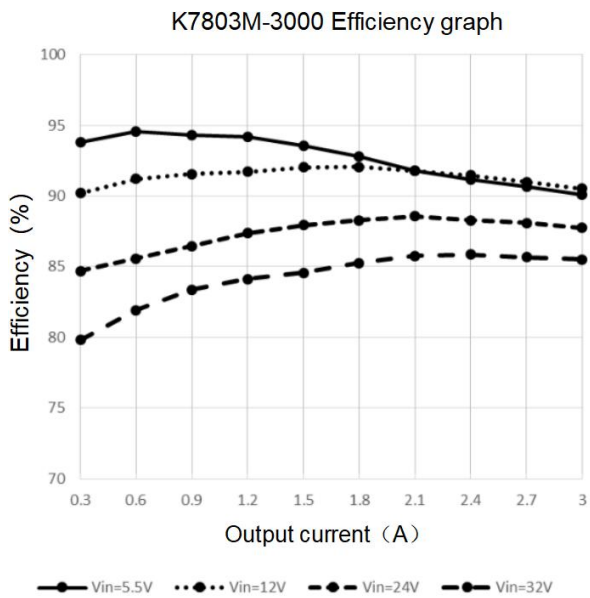
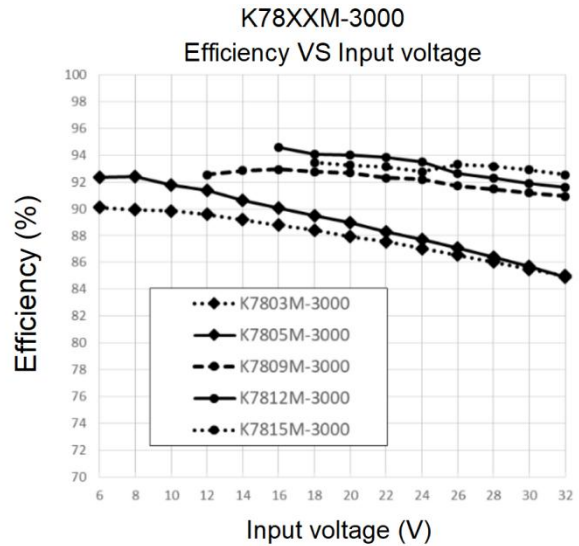
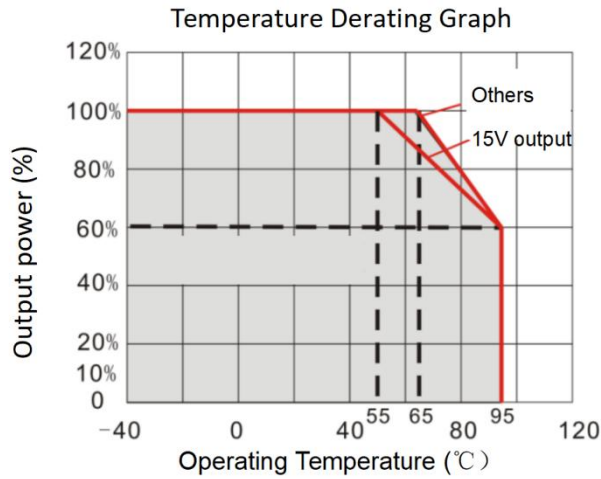

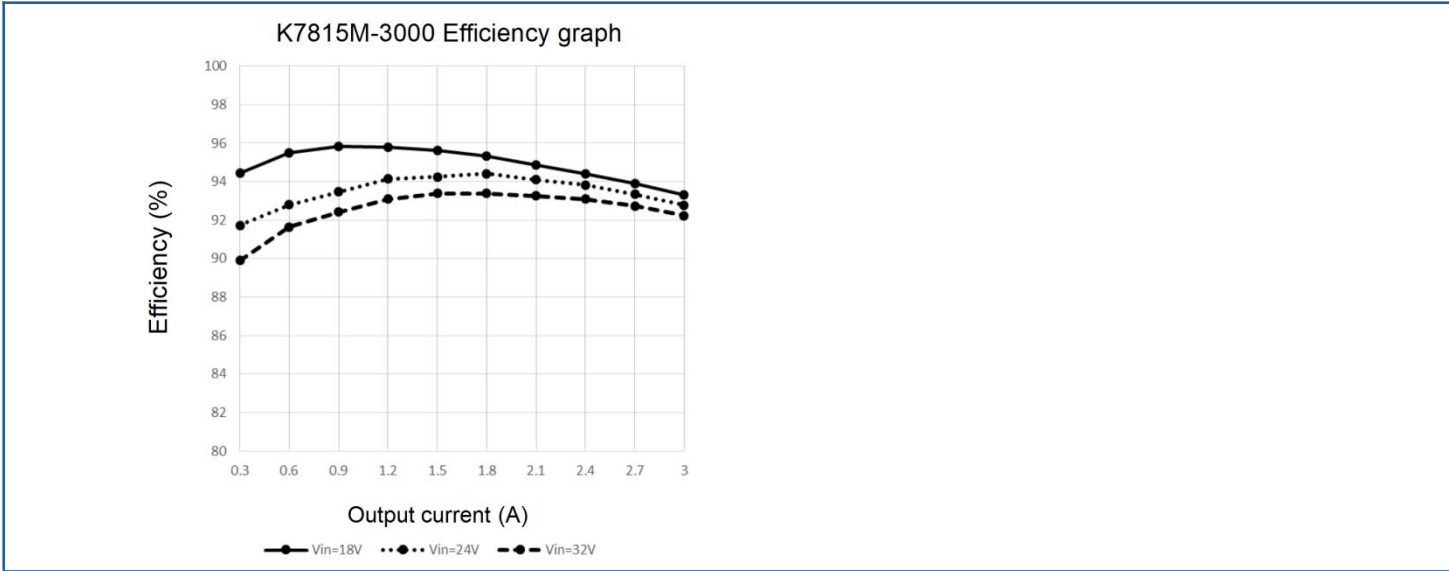

Recommended Circuits for Application

➤ **Output Load Requirements**

The maximum capacitive load of the product is determined by nominal full-load testing. Do not exceed the maximum capacitive load at the output terminals during operation, as this may cause startup difficulties and potentially damage the product.

➤ **Recommended Circuit**

To effectively reduce input/output ripple and noise, connect a capacitive filter network to the input and output terminals. Refer to Figure 1 for the application circuit. The negative output application circuit is shown in Figure 2 below, while the parallel application circuit for both positive and negative outputs is shown in Figure 3 below (with the recommended LDM value of 10μH in the figure). However, appropriate filter capacitors should be selected. Excessively large capacitors may affect product startup. To ensure each output channel operates under safe and reliable conditions, the recommended capacitive load values are detailed in Table 1 below. (Capacitance values for C1 and C2 should refer to the external capacitor table. They may be appropriately increased as needed, or low ESR tantalum capacitors and electrolytic capacitors may be used.)

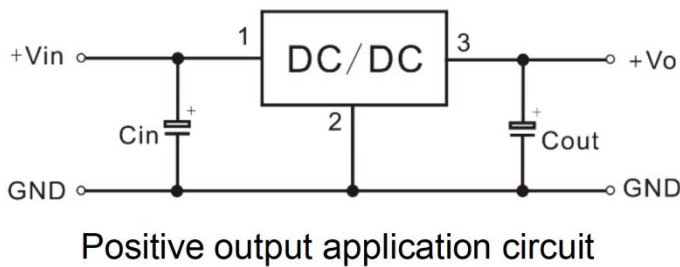

Figure 1

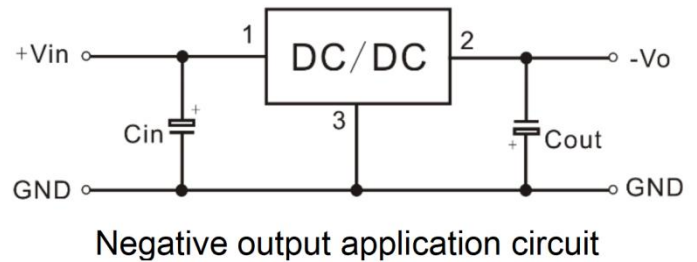

Figure 2

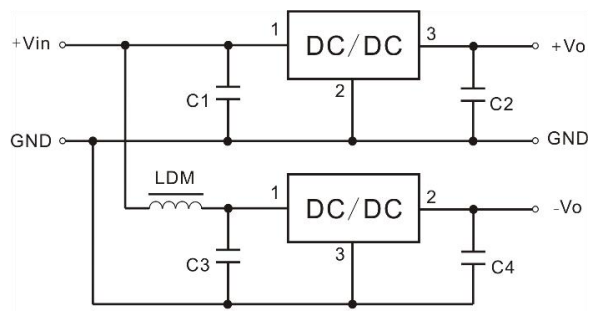
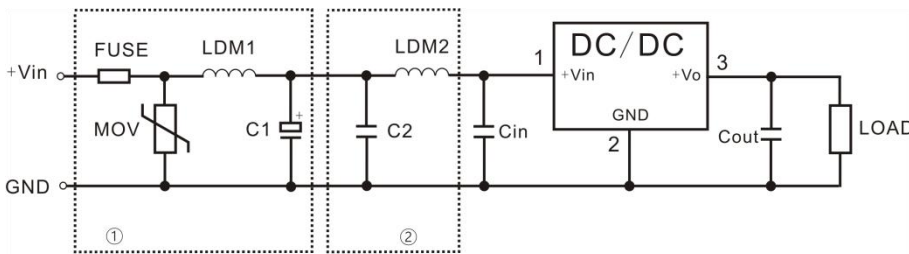

Figure 3 (Positive & negative outputs connected in parallel application circuit diagram)

Part No.	Recommended Capacitive Load Values (Table 1)			
	Cin (Electrolytic Capacitor)	C1/C3 (Ceramic Capacitor)	Cout (Electrolytic Capacitor)	C2/C4 (Ceramic Capacitor)
K7803M-3000	47μF/50V	22μF/50V	100μF/16V	47μF/10V
K7805M-3000	47μF/50V	22μF/50V	100μF/16V	47μF/10V
K7809M-3000	100μF/50V	47μF/50V	220μF/16V	47μF/16V
K7812M-3000	100μF/50V	47μF/50V	220μF/25V	47μF/25V
K7815M-3000	100μF/50V	47μF/50V	220μF/25V	47μF/25V

1. Recommended EMC circuit diagrams

Positive output circuit diagram



Note: The part ① circuit is for EMC test, part ② for EMI filtering, both can be adjusted according to the actual situation

FUSE	Select based on actual need
MOV	20D330K
C1	680μF/50V
C2	4.7μF/50V
Cin/Cout	See Table 1
LDM1	82μH
LDM2	6.8μH

Negative output circuit diagram

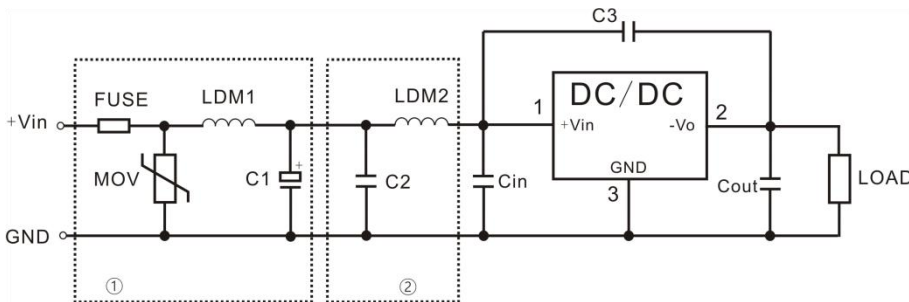

Note: The part ① circuit is for EMC test, part ② for EMI filtering, both can be adjusted according to the actual situation

FUSE	Select based on actual need
MOV	20D470K
C1	680μF/50V
C2/C3	4.7μF/50V
Cin/Cout	Refer to Table 1
LDM1	82μH
LDM2	6.8μH

Application Notice

1. This product cannot be used in parallel and does not support Hot Plugging;
2. The product must be used within its specified parameters; otherwise, permanent damage may occur;
3. Performance specifications outlined in this manual cannot be guaranteed if the product operates below the minimum required load;
4. Performance compliance with all specifications in this manual cannot be guaranteed if the product operates beyond its load range;
5. Unless otherwise specified, all data above is measured at Ta=25°C, humidity <75%, nominal input voltage, and rated output load (pure resistive load);
6. All testing methods for the above specifications comply with our company's standards;
7. The above specifications apply to the product models listed in this manual. Non-standard models may exceed certain requirements; please contact our technical staff for specific details.

8. Customized products are available upon request.

Guangzhou Aipu Electron Technology Co., Ltd

Address: Building 4, HEDY Park, No.63, Punan Road, Huangpu Dist, Guangzhou, China.

Tel: 86-20-84206763 Fax: 86-20-84206762 HOTLINE: 400-889-8821

E-mail: sales@aipu-elec.com Website: www.aipupower.com